

FLOOR PLAN
(TANK BASE)

NOTE: ADDITIONAL BAFFLE FOR GREASE INTERCEPTOR.

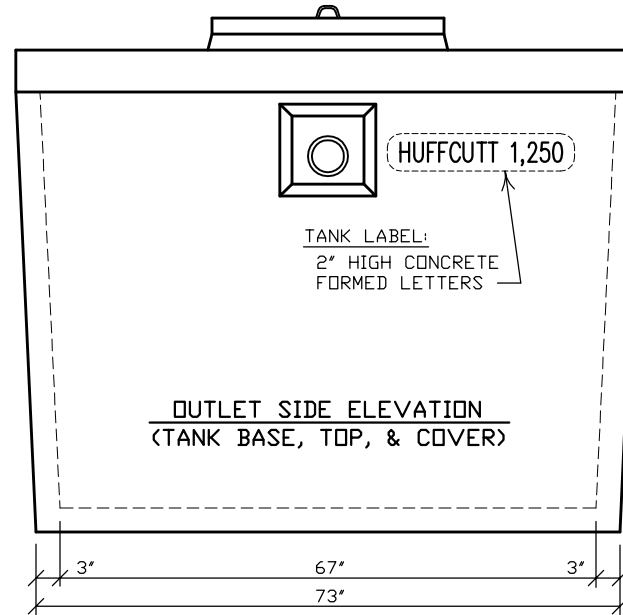

OUTLET SIDE ELEVATION
(TANK BASE, TOP, & COVER)

N.P.C.A. CERTIFIED PLANT
&
MEMBER OF:
NATIONAL & WISCONSIN PRECAST CONCRETE ASSOCIATIONS

THIS DRAWING SHALL NOT
BE COPIED OR SUBMITTED
TO OTHERS WITHOUT THE
CONSENT OF THIS COMPANY.

HUFFCUTT CONCRETE, INC. 4154 123rd STREET
CHIPPEVA FALLS, WI 54729
(715) 723-7446 * FAX (715) 723-7111 * (800) 924-1516 * www.huffcutt.com

TANK:
1,250 GAL. LDW PROFILE
PUMP, SEPTIC, HOLDING,
OR GREASE INTERCEPTOR

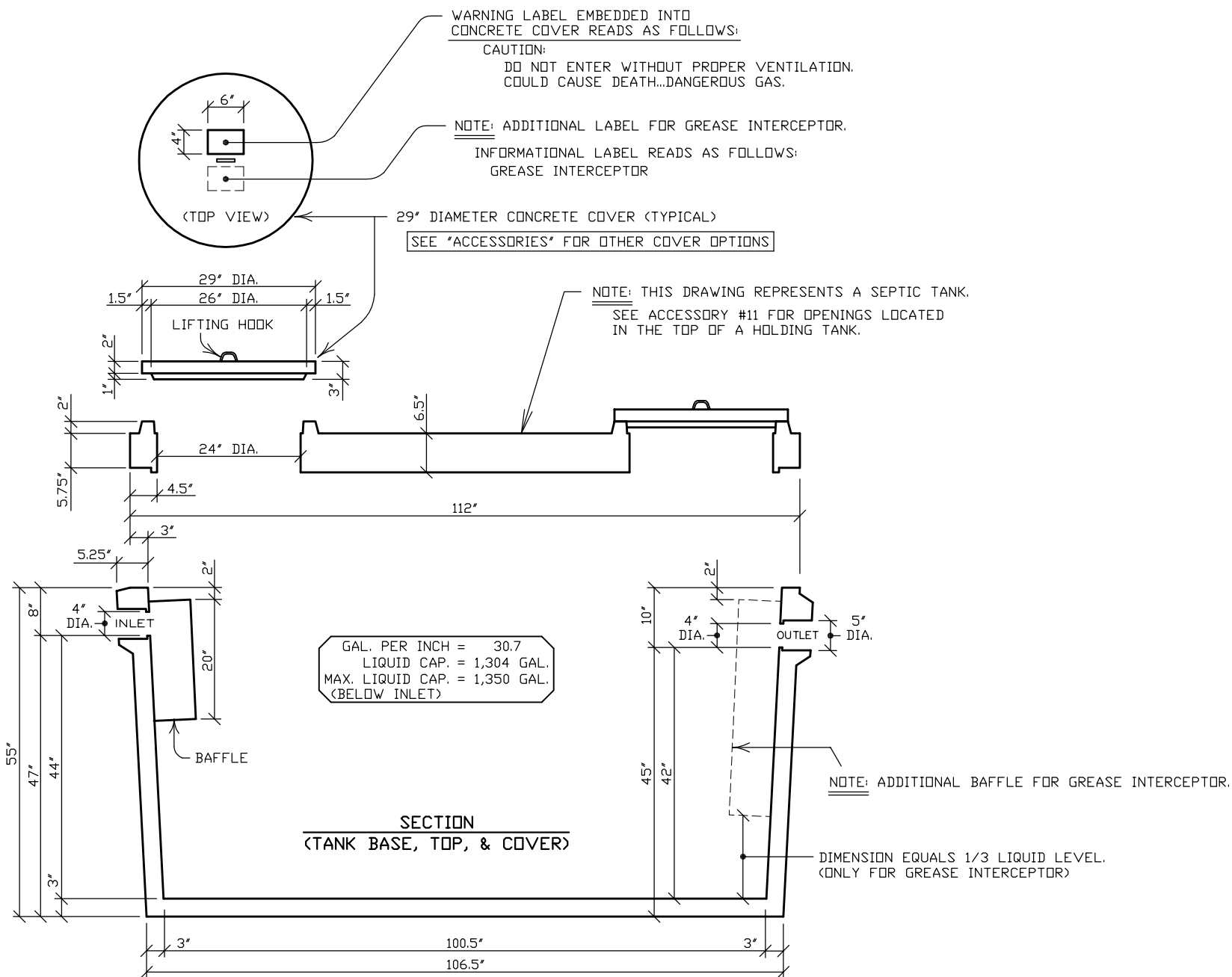

N.P.C.A. CERTIFIED PLANT
 &
 MEMBER OF:
 NATIONAL & WISCONSIN PRECAST CONCRETE ASSOCIATIONS

THIS DRAWING SHALL NOT
 BE COPIED OR SUBMITTED
 TO OTHERS WITHOUT THE
 CONSENT OF THIS COMPANY.

HUFFCUTT
 CONCRETE, INC.
 4154 123rd STREET
 CHIPPEWA FALLS, WI 54729
 (715) 723-7446 * FAX (715) 723-7111 * (800) 924-1516 * www.huffcutt.com

TANK:
 1,250 GAL. LDW PROFILE
 PUMP, SEPTIC, HOLDING,
 OR GREASE INTERCEPTOR

